

# NI PXI-1042 POWER SUPPLY SHUTTLE USER GUIDE

The NI PXI-1042 power supply shuttle is a replacement part for the PXI-1042 chassis.

## Introduction

---

To minimize downtime caused by a power-supply failure, the PXI-1042 chassis has a modular power supply shuttle. This power supply shuttle includes the chassis power supply, cooling fans, and fan-control circuitry. Key features of the power supply shuttle include:

- Universal AC input with automatic voltage and frequency ranging
- Over-current protection via push-reset circuit breaker
- Remote power monitoring and inhibit via a rear-panel connector
- Temperature-sensing module that can adjust fan speed based on air-intake temperature to minimize audible noise
- Circuitry to control a front-panel LED that indicates power supply failure

## Unpacking

---

Carefully inspect the shipping container and the power supply shuttle for damage. Check for visible damage to the metal work. Check to make sure all handles, hardware, and switches are undamaged. Visually inspect the inside of the shuttle for any possible damage, debris, or detached components. If damage appears to have been caused during shipment, file a claim with the carrier. Retain the packing material for possible inspection and/or reshipment.

---

National Instruments™, NI™, and ni.com™ are trademarks of National Instruments Corporation. Product and company names mentioned herein are trademarks or trade names of their respective companies. For patents covering National Instruments products, refer to the appropriate location: **Help»Patents** in your software, the `patents.txt` file on your CD, or [ni.com/patents](http://ni.com/patents).

October 2002  
323499A-01

# What You Need to Get Started

- ❑ PXI-1042 chassis (the unit being repaired)
- ❑ PXI-1042 power supply shuttle
- ❑ *Read Me First: Safety and Radio-Frequency Interference*
- ❑ *NI PXI-1042 User Manual* (provided with the chassis; also available at [ni.com/support](http://ni.com/support))
- ❑ #1 Phillips screwdriver

## Description

Refer to Figure 1 to locate user-accessible components on the power supply shuttle.

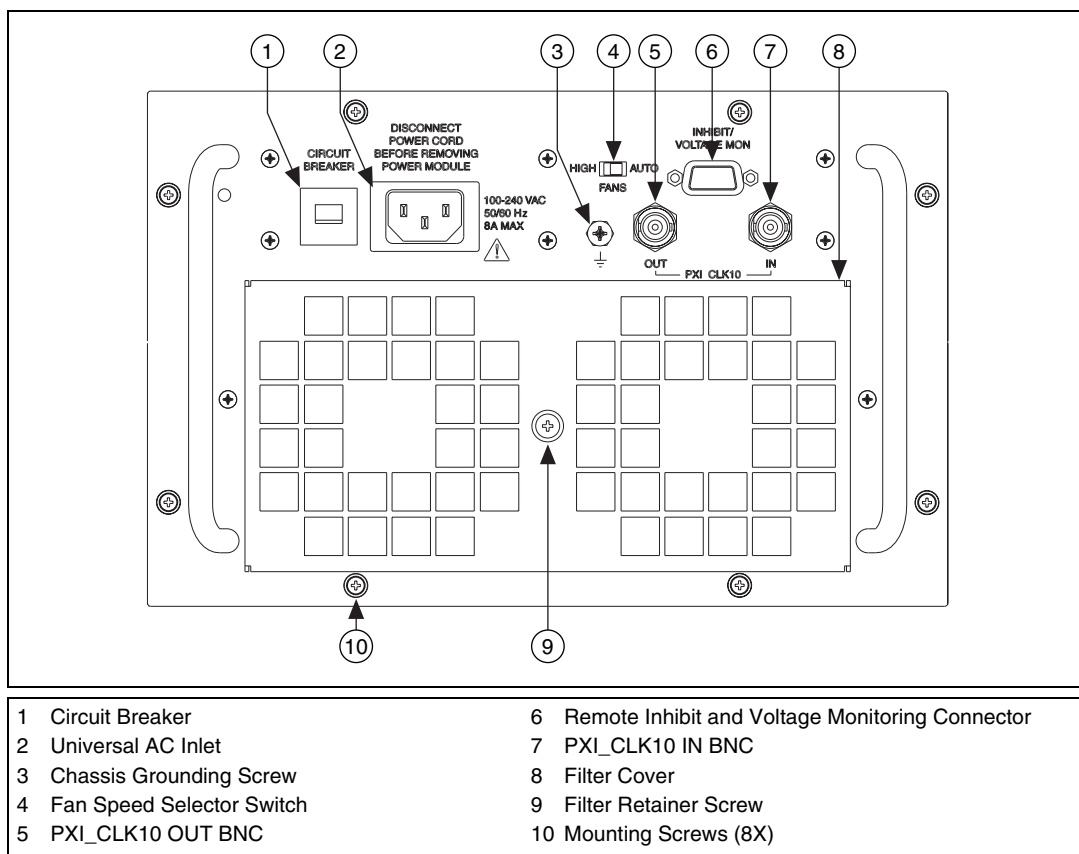

**Figure 1.** PXI-1042 Power Supply Shuttle Rear Panel

# Installation and Maintenance

---

The information in this section is for qualified service personnel only. Read the *Read Me First: Safety and Radio-Frequency Interference* document included with your kit before using the power supply shuttle.



**Caution** Many components within the PXI-1042 chassis under repair are susceptible to static discharge damage. Service the chassis only in a static-free environment. Observe standard handling precautions for static-sensitive devices while servicing the chassis. Always wear a grounded wrist strap, or equivalent, while servicing the chassis.



**Caution** Always disconnect the AC power cable before cleaning or servicing the chassis.



**Caution** Never connect the AC power cable to the power supply shuttle until you install it in a PXI-1042 chassis. Do not use, test, or configure the power supply shuttle outside of a chassis.

The power supply shuttle is a replacement part for the PXI-1042 chassis. The *NI PXI-1042 User Manual* contains all of the most up-to-date chassis service procedures, including removal and replacement of power supply shuttles. The chassis includes a hardcopy of the *NI PXI-1042 User Manual*; additionally, you can download a softcopy from [ni.com/support](http://ni.com/support).

## Removal

Before attempting to replace the power supply shuttle, verify that there is adequate clearance behind the chassis. Set the power switch on the front panel to the Off (nonrecessed) position and disconnect the power cable from the power supply shuttle on the back of the chassis. Identify the eight captive mounting screws that attach the power supply shuttle to the chassis. Refer to Figure 1 for the mounting screw locations. Using a Phillips screwdriver, loosen the captive mounting screws. Pull on the two rear handles of the power supply shuttle to remove it from the back of the chassis.

## Installation

Ensure that there is no visible damage to the new power supply shuttle. Verify that the housing and connector on the new power supply shuttle have no foreign material inside. Remove the protective cap on the PXI\_CLK10 connector. Install the new power supply shuttle into the opening on the rear of the chassis. Tighten the eight captive mounting screws with a Phillips screwdriver.

# Configuration

The fan-speed selector switch is on the rear panel of the power supply shuttle. Refer to Figure 1 to locate the fan-speed selector. Select HIGH for maximum cooling performance (recommended) or AUTO for quieter operation. When set to AUTO, air-intake temperature determines the fan speed.

## Connecting Safety Ground



**Caution** The power supply shuttle is designed with a three-position NEMA 5-15 jack that connects the ground line to the chassis ground. To minimize shock hazard, make sure the electrical power outlet you use to power the chassis has an appropriate earth safety ground.

If your power outlet does not have an appropriate ground connection, you must connect the premise safety ground to the chassis grounding screw. Refer to Figure 1 to locate the chassis grounding screw. To connect the safety ground, complete the following steps:

1. Connect a 16 AWG (1.3 mm) wire to the chassis grounding screw using a grounding lug. The wire must have green insulation with a yellow stripe or must be noninsulated (bare).
2. Attach the opposite end of the wire to permanent earth ground using toothed washers or a toothed lug.

# Specifications

---

## AC Input

Input voltage range .....	100 to 240 VAC
Operating voltage range <sup>1</sup> .....	90 to 264 VAC
Input frequency .....	50/60 Hz
Operating frequency range <sup>1</sup> .....	47 to 63 Hz
Input current rating .....	8 A
Over-current protection .....	10 A circuit breaker
Line regulation	
3.3 V .....	<±0.2%
5 V .....	<±0.1%
±12 V .....	<±0.1%

---

<sup>1</sup> The operating range is guaranteed by design.

Efficiency ..... 70% typical

Power disconnect ..... The AC power cable provides main power disconnect. The chassis front-panel power switch causes the power supply to provide DC power to the CompactPCI/PXI backplane.

## DC Output

DC current capacity ( $I_{MP}$ )

Voltage	$I_{MP}$ (Steady-State Current)
+3.3 V	20 A
+12 V	4 A
+5 V	29 A
-12 V	2 A

Load regulation

Voltage	Load Regulation
+3.3 V	<5%
+12 V	<5%
+5 V	<5%
-12 V	<5%

Maximum ripple and noise (20 MHz bandwidth)

Voltage	Maximum Ripple and Noise
+3.3 V	50 mV <sub>pp</sub>
+12 V	120 mV <sub>pp</sub>
+5 V	50 mV <sub>pp</sub>
-12 V	120 mV <sub>pp</sub>

Over-current protection..... All outputs protected from short circuit and overload with automatic recovery

Over-voltage protection

- 3.3 V and 5 V.....Clamped at 20 to 30% above nominal output voltage
- +12 V and -12 V .....Clamped at 26 to 29 V difference between +12 and -12 V outputs

Power supply shuttle MTTR.....Replacement in under 5 minutes